

1

2

3

4

5

6

A

A

B

B

C

C

D

D

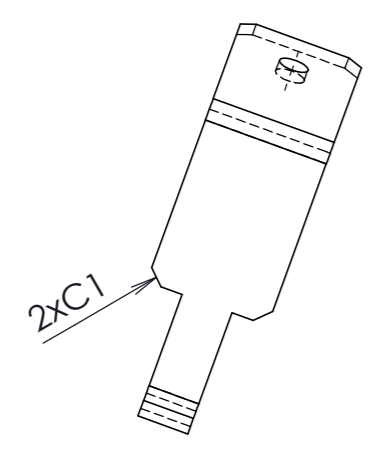

図面ビュー A

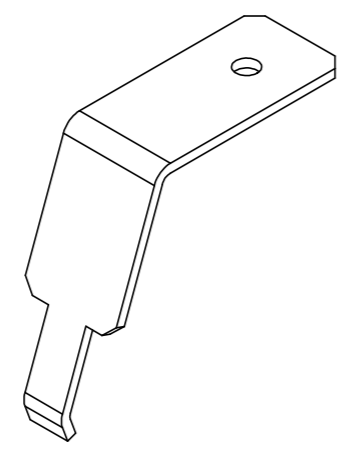
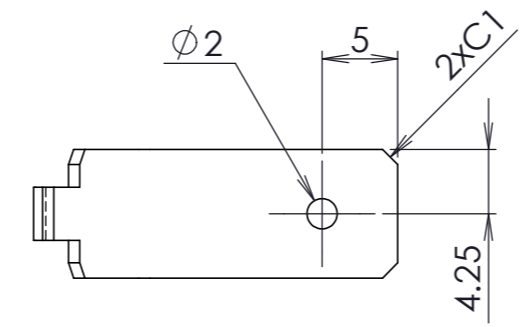
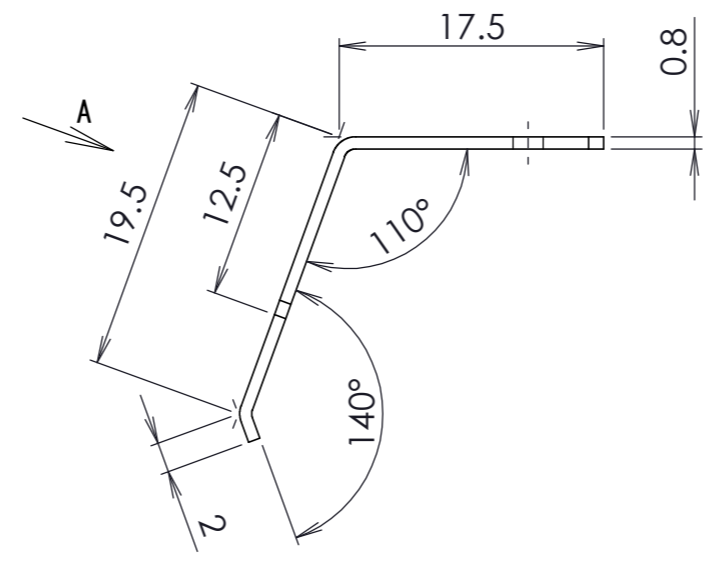
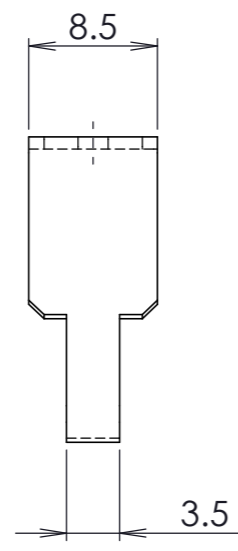

- 3. 指示なき各コーナー部C0.3~0.5
- 2. 指示なき寸法公差: JIS中級(m)
- 1. T=0.8 レーザー加工 曲げ加工

		DESCRIPTION		
MATERIAL	SURFACE TREATMENT	HEAT TREATMENT	QTY	
SUS304(H)				
SHEET	2:1	DESIGNED	CHECKED	APPROVED
	 3 ANGLE			

1

2

3

4

5

6