

1

2

3

4

5

6

▽ (  ,  )

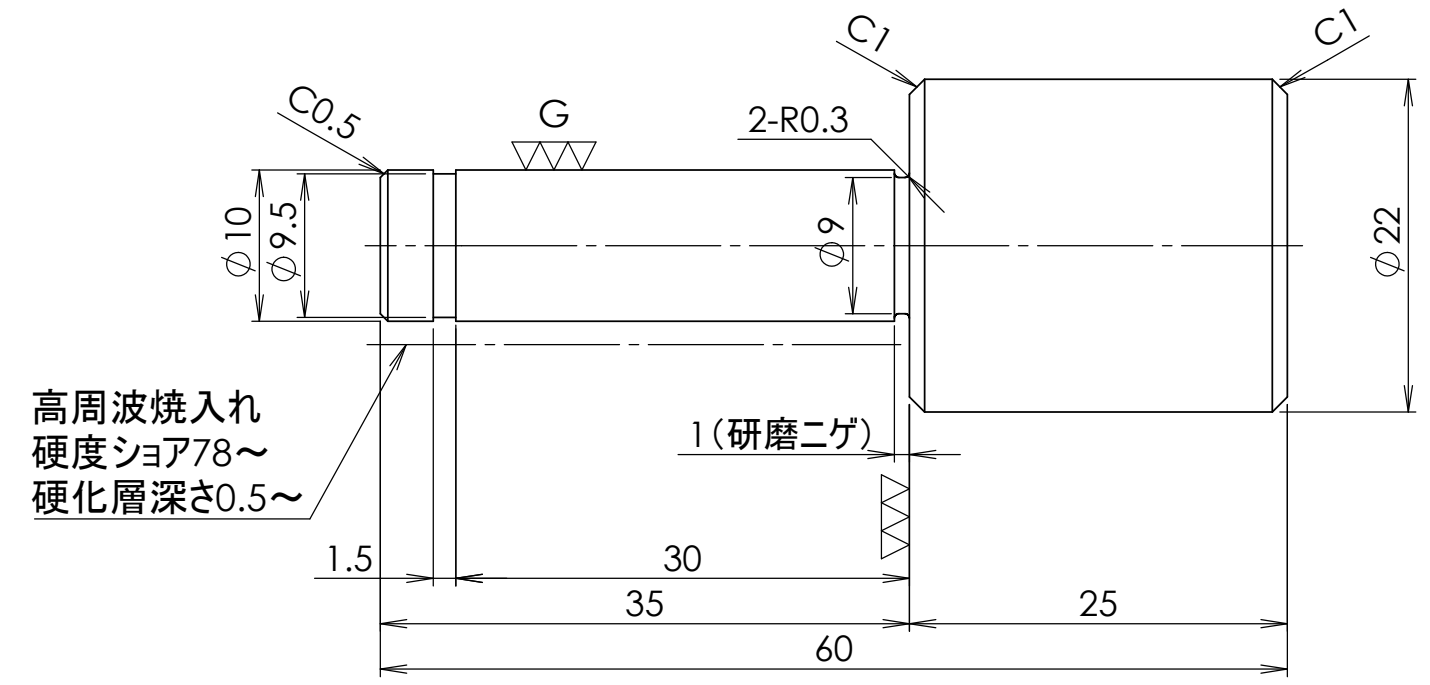

高周波焼入れ  
硬度シヨア78~  
硬化層深さ0.5~

1 (研磨ニゲ)

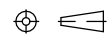
		DESCRIPTION		
MATERIAL	SURFACE TREATMENT	HEAT TREATMENT	Q'TY	
SUJ2		高周波焼入れ	.	
SHEET	2:1	DESIGNED	CHECKED	APPROVED
				
	3 ANGLE			

図番 : 2405-0150J-5