

1

2

3

4

5

6

A

B

C

D

A

B

C

D

Ra6.3

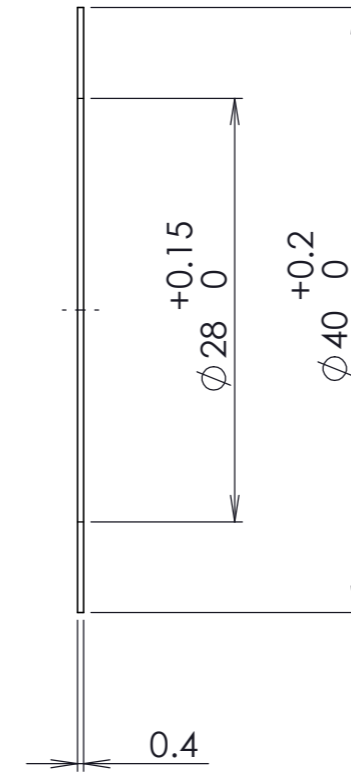
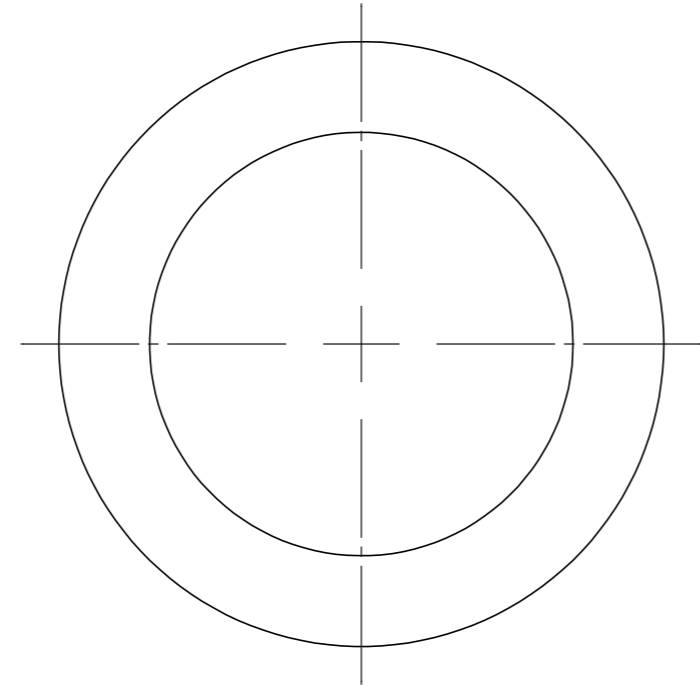

2. 指示なき寸法公差: JIS中級 (m)  
 1. T=0.4 レーザー加工

		DESCRIPTION		
MATERIAL	SURFACE TREATMENT	HEAT TREATMENT	Q'TY	
SUS304-CSP				
SHEET	2:1	DESIGNED	CHECKED	APPROVED
	 3 ANGLE			

1

2

3

4

5

6