

1

2

3

4

5

6

A

A

B

B

C

C

D

D

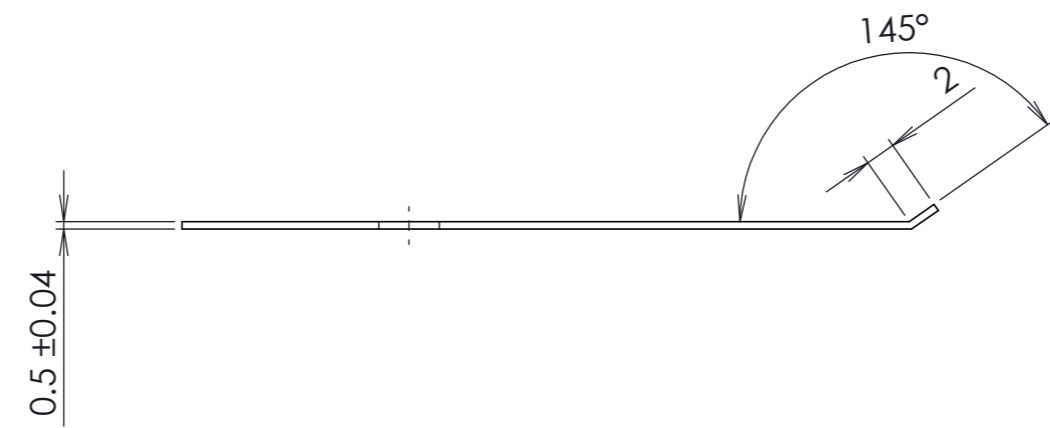
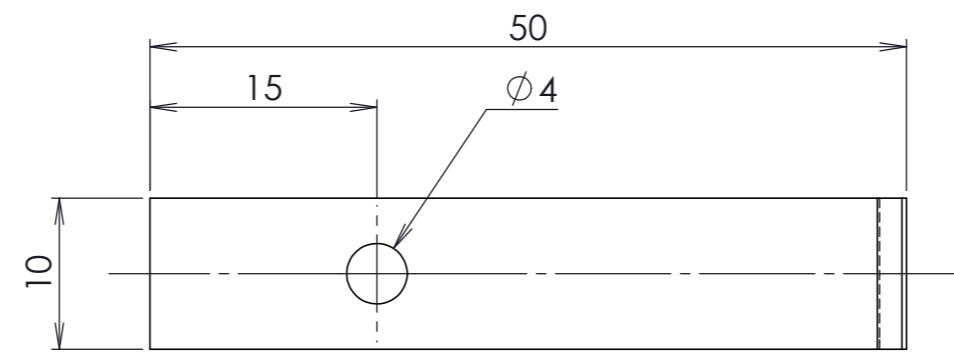

2. 指示なき寸法公差: JIS中級 (m)  
 1.T=0.5 ± 0.04 レーザー加工 曲げ加工

		DESCRIPTION		
MATERIAL	SURFACE TREATMENT	HEAT TREATMENT	Q'TY	
C2801P				
SHEET	2:1	DESIGNED	CHECKED	APPROVED
	 3 ANGLE			

1

2

3

4

5

6