

$\sqrt{Ra\ 12.5}$   
 (  $\sqrt{Ra\ 0.8}$  )

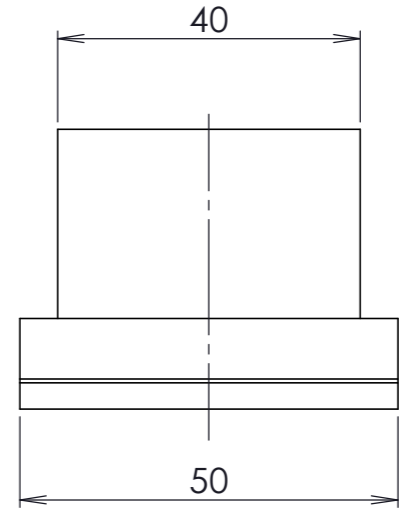
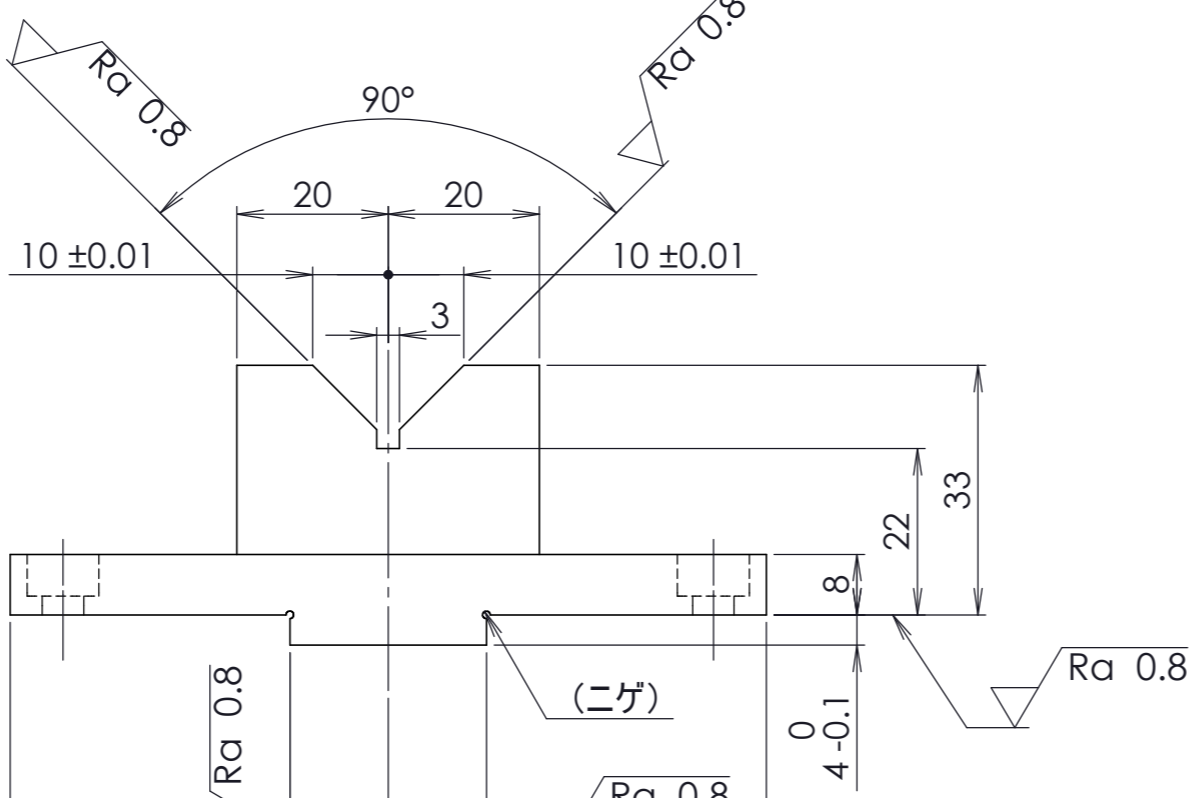
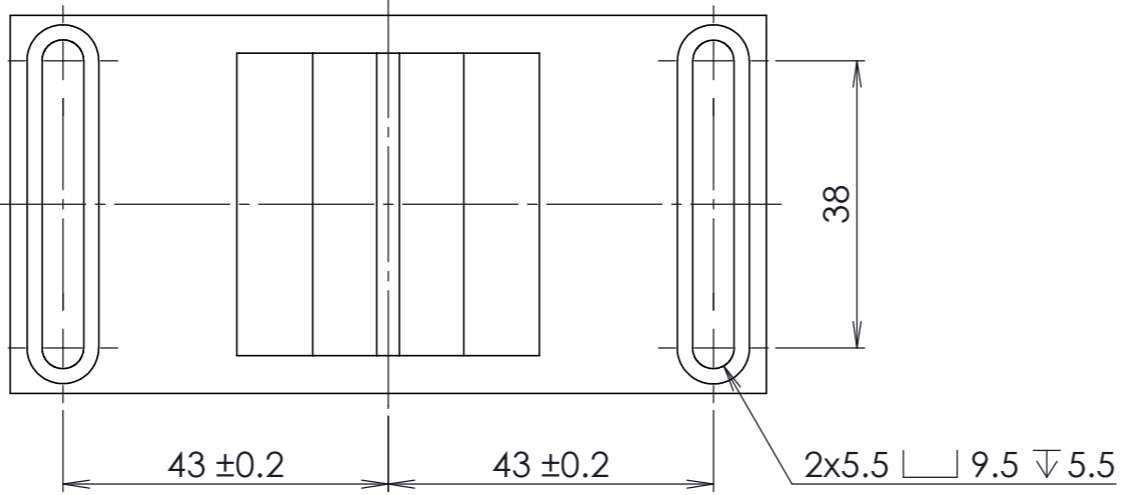

1. 指示なき公差はJIS中級(m)

		DESCRIPTION		
MATERIAL		SURFACE TREATMENT	HEAT TREATMENT	Q'TY
SKS3		硬質クロムメッキ(フラッシュ)	焼入-低温焼戻し HQ-HTL HRC56-64	.
SHEET	1:1	DESIGNED	CHECKED	APPROVED
	 3 ANGLE	.	.	.