

▽ Ra6.3 (▽ Ra1.6)

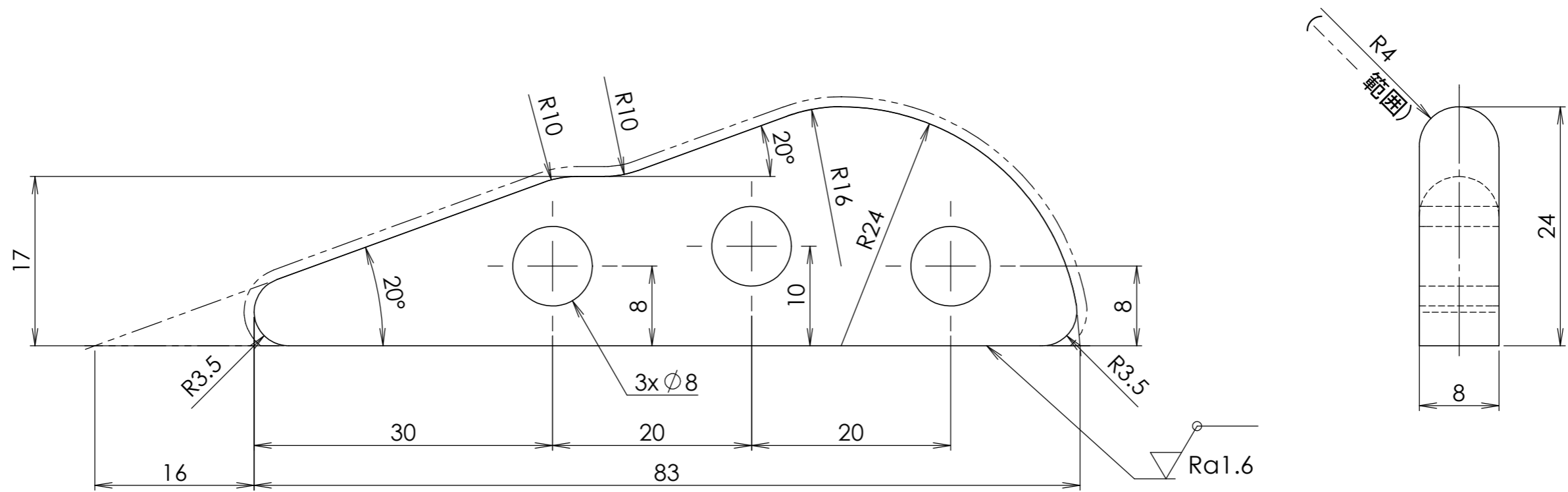

1.指示なき角は全てR0.5

寸法許容差		MATERIAL	SURFACE TREATMENT	HEAT TREATMENT	Q'TY
30 以下	±0.1	SKD11	炭化チタンコーティング	全体焼入れ(ズブ焼入れ)HRC58~60	.
30こえ 100以下	±0.2	SHEET	2:1	DESIGNED	CHECKED
こえ 以下	±				APPROVED
こえ 以下	±		⊕		
角度公差	±1°		3 ANGLE		

DESCRIPTION