

1

2

3

4

5

6

A

A

B

B

C

C

D

D

Ra12.5

31x ϕ 4.5 通し
 \square ϕ 8 ∇ 4.5

1220

30xP40=1200

10

40

5.2

(4.5)

(24.8)

30

1.指示なき公差はJIS中級(m)

		DESCRIPTION		
MATERIAL	SURFACE TREATMENT	HEAT TREATMENT	Q'TY	
A5052				
SHEET	2:1	DESIGNED	CHECKED	APPROVED
	ϕ ∇ 3 ANGLE			

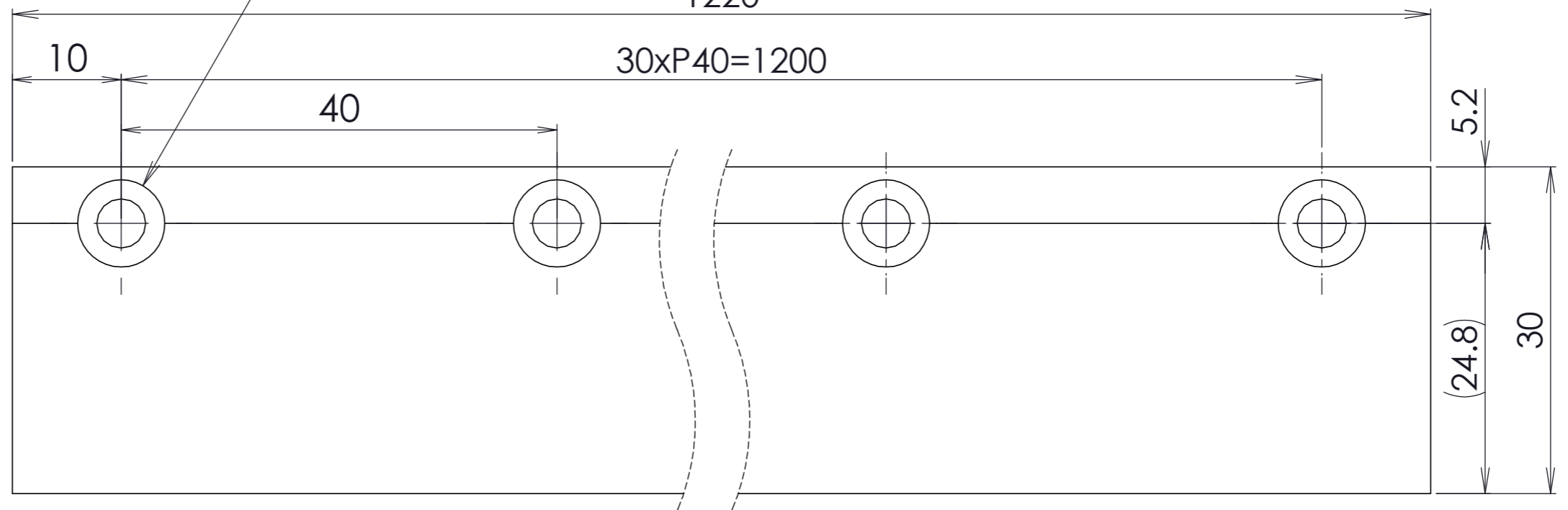
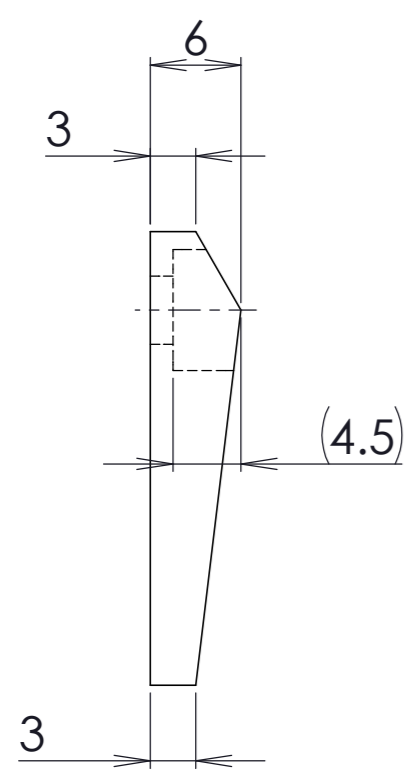

1

2

3

4

5

6